

# Optiva OTS-ODLS 22 GHz, 40 $\mu$ s max Internal Fiber Delay Line System

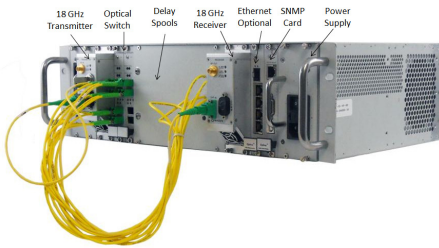

DATASHEET | APRIL 2014

MICROWAVE



## Applications

- Radar System Testing
- Phase Array Antennas
- Signal Processing
- Electronic Warfare (EW) Systems

## Features

- 40  $\mu$ sec Delays Max
- Switching Option Available
- Smaller Size and Less Weight - Conserve Rack Space
- 0.05 - 22 GHz Bandwidth
- Flat Phase Response
- Minimal Triple-Transit Echoes
- Low Link Loss Options
- Low Temperature Sensitivity
- Manually and/or Computer Controlled

The Optiva OTS-ODLS, 22 GHz Internal Fiber Delay Line System is designed for use with Optiva OTS-2 22 GHz transmitter, receiver, optical switches, and EDFA's. The optical switches allow for up to four separate delays to be used with a maximum delay time of 40  $\mu$ s. The system delivers unmatched performance for radar testing, signal processing, phased array antennas and phase noise testing with greater flexibility than traditional coax or waveguide solutions.



EMCORE's fiber optic delay lines provide bandwidth that is essentially independent of fiber length, losses or delays, and triple transit signals that are immeasurable. In addition to enhanced electrical performance, the delay lines provide several mechanical advantages. EMCORE's technology takes advantage of the rigid yet flexible properties of fiber optic cable to provide repeatable enhanced phase and group delay characteristics.

The Optiva OTS-ODLS provides convenient RF input/outputs to connect to the OTS-2 RF transmitter and receiver. Internally, the RF signal is converted to an optical signal and transmitted over a fiber optic link to the receiver and provides the required signal delay time. Delay length and link performance requirements can be tailored over a range of performance levels to meet specific requirements. The Optiva OTS-ODLS system allows for a long delay in a relatively compact package with the superior temperature stability of fiber.

EMCORE's Optiva OTS-ODLS 22 GHz internal fiber delay line system can be supplied as a complete solution with all modules mounted in a 19" Optiva rack-mount enclosure utilizing standard AC power. The Optiva OTS-ODLS family of internal fiber delay lines also includes 18 GHz and 40 GHz frequency options and external Optiva fiber delay line systems for greater delay lengths are available.

## System Design

The Optiva platform includes a wide range fiber **optiva** PLATFORM optic transport solutions for satellite and microwave communications applications including transparent inter- and intra-facility links, video transport, antenna remoting, radar system testing, phased array antennas, signal processing, electronic warfare systems and other high-dynamic-range applications.

Optiva is a completely modular, hot-swappable platform with a variety of rack-mount or compact tabletop, or wall-mountable enclosures are available. The 3 RU 19" rack-mount, fan-cooled enclosure (Model OT-CC-16F) for the OTS-ODLS internal fiber delay line system can support up to 16 insert cards and utilizes two dual-redundant, hot-swappable, 200 watt power supplies.

# Optiva OTS-ODLS 22 GHz, 40 μs max Internal Fiber Delay Line System

## Specifications

Typical RF Characteristics/Standard Features measured with OTS-2 Tx and OTS-2 Rx

Parameter	Value	Unit	Comments
Frequency Range	0.05-22	GHz	
Delay Range	3 to ≤40	μsec	
Delay Tolerance	< +/-2	%	
Phase Stability	$\Delta\phi \leq 2^\circ$ per 10 sec	--	Typical for 40 μs DLS
RF Input Level	0 to 16	dBm	Typical
Deviation from Linear Phase	$\leq 10^\circ$	--	Typical (up to 22 GHz)
Amplitude Flatness	$\leq +/-3$	dB	 Typical
Amplitude Linearity	$\leq +/-1$	dB	
Gain (@ RF in = 0 dBm)*	$\leq -10$	dB	
Return Loss/VSWR	$R_L > 15$ $\leq 1.43:1$	dB	
Spur Level	$\leq -60$	dBc	
Input 1 dB Compression Point	$\geq +16$	dBm	
2nd Harmonic (@ RF <sub>in</sub> = 0 dBm)	$\leq -45$	dBc	
Noise Figure	$\leq 70$	dB	
RF Connectors	SMA -K	--	

\*0 dB gain is based upon a single 40 μs delay spool and receiver with 35 dB post amplifier. Actual system gain will vary based upon system requirements.

## Environmental Specifications

Parameter	Symbol	Min	Max	Units
Operating Temperature	T <sub>OP</sub>	-10	50	°C
Operating Humidity, Maximum Non-Condensing	-	-	95	%
Operating Altitude, Above Sea Level	.	-	6000 1828	ft m
Storage Temperature	T <sub>STG</sub>	-40	70	°C
Storage Humidity, Maximum Non-Condensing	.	-	95	%
Storage Altitude, Above Sea Level	-	-	50,000 15,240	ft m

## Block Diagram - Four Delays System Option

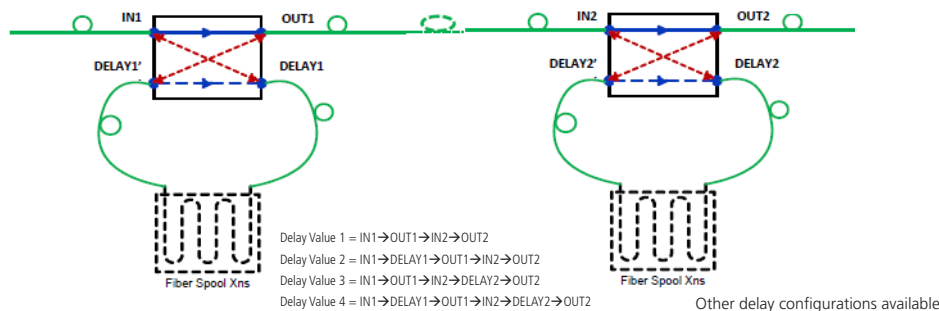

## Enclosure Options



OT-CC-16F

## Power Consumption - Max

Model	Input Voltage (VAC)	Wattage (@+50°C)
OTS-ODLS-I	120 / 240	200 W

# Optiva OTS-ODLS 22 GHz, 40 $\mu$ s max Internal Fiber Delay Line System



DATASHEET | APRIL 2014

MICROWAVE

## Order Information

Delay System
OTS-ODLS-I-22-V/XX-Y-ZZ

- When ordering replace "V" with one of the Switching Options
- When ordering replace "XX" with one of the Optical Connector Options
- When ordering replace "Y" with one of the RF Output Options
- When ordering replace "ZZ" with one of the Gain Options
- Delay Time Options\* must be defined by Customer

Switching Options (0 to 4) "V"	Optical Connector Options "XX"	RF Output Options "Y"	Link Gain RF Amplifier Options "ZZ"
Standard: 0 = no Switching	Standard: SA = SC / APC	1 = Fixed Output EDFA in Rx	00 = No RF Amp 01 = RF Amp
Optional: 1 = One Delay 2 = Two Delays 3 = Three Delays 4 = Four Delays	Optional: FA = FC / APC EA = E2000 / APC	2 = Variable Output No EDFA in Rx	

Delay Time Options* (50 ns to 40 $\mu$ s)
Standard: 1 Delay = XXXXXX (XXXXXX) = 1000/100/10/1/1/01
Optional: 1st Delay = XXXXXX (XXXXXX) = 1000/100/10/1/1/01 2nd Delay = XXXXXX (XXXXXX) = 1000/100/10/1/1/01 3rd Delay = XXXXXX (XXXXXX) = 1000/100/10/1/1/01 4th Delay = XXXXXX (XXXXXX) = 1000/100/10/1/1/01

## Laser Safety

This product meets the appropriate standard in Title 21 of the Code of Federal Regulations (CFR). FDA/CDRH Class 1M laser product. This device has been classified with the FDA/CDRH under accession number 0220191. All versions of this laser are Class 1M laser product, tested according to IEC 60825-1:2007 / EN 60825-1:2007. An additional warning for Class 1M laser products. For diverging beams, this warning shall state that viewing the laser output with certain optical instruments (for example: eye loupes, magnifiers, and microscopes) within a distance of 100 mm may pose an eye hazard. For collimated beams, this warning shall state that viewing the laser output with certain instruments designed for use at a distance (for example: telescopes and binoculars) may pose an eye hazard.

Wavelength = 1.3/1.5  $\mu$ m.

Maximum power = 30 mW.

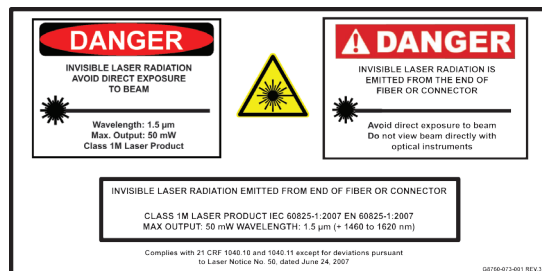

\*Caution - Use of controls or adjustments or performance of procedures other than those specified herein may result in hazardous radiation exposure.

\*IEC is a registered trademark of the International Electrotechnical Commission.