

OTP-1DVI2A1SU

DVI / VGA / RGBHV / RGB, Analog & Digital Audio, RS-232 & USB KM



DATASHEET FIBER OPTICS



Features

- Format conversion: D-to-A or A-to-d
- RS-232 Serial Data & USB Keyboard/Mouse
- Supports Real Time Video up to 1080p@60Hz
- Full EDID over Duplex Data Stream
- Supports component video (RGBHV / RGB)
- Video Scaling to Display's Native resolution up to 1600x1200
- Video loop back on Transmitter
- 3.5 mm analog & S/PDIF Audio Support
- Multimode or singlemode fiber options (up to 70Km over one fiber)
- 3-Year Warranty

Applications

- Digital signage / remote kiosks
- Control room
- Digital cinema

Enclosure Options

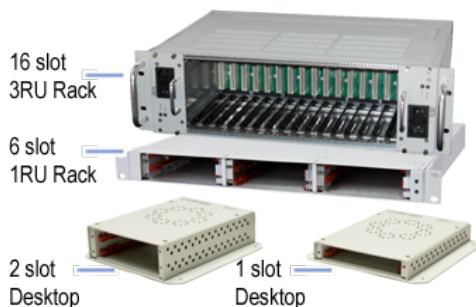

DVI with Audio & Serial Data Transmission over Fiber

The Optiva OTP-1DVI2A1SU provides for the transmission of 1 channel of single- or dual-link DVI video, 2 channels of analog audio and RS-232 serial data, over long or short distances, using a single fiber.

In addition, the OTP-1DVI2A1SU is part of our innovative Optiva video, audio and data media transport system. Optiva was designed to maintain lossless fiber extension between input and output signals. New signals may be added without the need for additional fiber through our proprietary daisy-chain technology. The Optiva line of products also includes insert cards for up to 16 channels of multiplexing / demultiplexing, 16x16 matrix switching, optical add/drop, as well as remote system monitoring.

System Design

Optiva insert cards support both 19" rackmount and compact tabletop or wall-mountable enclosures. The 3RU 19" rackmount enclosures (Models: OT-CC-16 & OT-CC-16F) can support up to 16 insert cards as well as dual-redundant, hot-swappable power supplies utilizing two 100 watt or two 200 watt power supplies. Also available in the rackmount form factor is our 1RU enclosure (Model: OT-CC-6-1U) which can accommodate six insert cards and utilizes two 60 watt power supplies. For desktop or wall mounting applications there are one-slot (Model: OT-DTCR-1) and two-slot (Model: OT-DTCR-2) enclosures. Both use an external wall mount power supply.



VGA	DVI	RGBHV	Resolutions	Max Refresh Rate (Hz)
•	•		640 x 480	VGA 85
		•	480i / 480p	30 / 60
•	•		800 x 600	SVGA 85
•	•		1024 x 768	XGA 85
•	•		1280 x 720	WXGA 85
		•	720p	60
•	•		1280 x 1024	SXGA 85
•	•		1400 x 1050	SXGA+ 75
•	•		1600 x 1200	UXGA 60 (VGA), 75 (DVI)
•	•		1680 x 1050	WSXGA+ 60
•	•		1920 x 1080	UXGA (1080p) 60 (VGA), 75 (DVI)
		•	1080i / 1080p	30 / 60
•	•		1920 x 1200	WUXGA 60 (VGA), 75 (DVI)
	•		2048 x 1536	QXGA 60
	•		2560 x 1600	WQXGA 60

■ Resolutions above 1080p 60Hz and 1920x1440 60Hz utilize Reduced Blanking Technology

U.S. Patent #'s 7720385 & 8064773

OTP-1DVI2A1SU

DVI / VGA / RGBHV / RGB, Analog & Digital Audio, RS-232 & USB KM



DATASHEET FIBER OPTICS

Ordering information

Transmitter	Receiver
OTP-1DVIT2AT1SUTR-XX/XX-YY	OTP-1DVIR2AR1SURT-XX/XX-YY
OTP-1DVIT2AT1SUTR-L4x3/L4x3-LC	OTP-1DVIR2AR1SURT-L4x3/L4x3-LC

- When ordering, replace "XXXX" with one of the optical codes specified below.
- For ordering, please substitute "YY" in the model for one of the following optical connectors: ST, FC, SC, or LC.

Optical Specifications

Optical Code	Fiber Type	Wavelength (nm)	Optical Budget (dB)	Distance (Km)
C0/C0	Multimode	850/850	7	0.2
C1/C1	Multimode	1310/1310	5	0.8
C2/C2	Singlemode	1310/1310	7	10
C2D/C2D	Singlemode	1310/1310	12	20
C2H/C2H	Singlemode	1310/1310	25	60
C3/C3	Singlemode	1550/1550	17	40
C3D/C3D	Singlemode	1550/1550	25	60
C1/C3M	Multimode	1310/1550	5	1.5
C2/C3	Singlemode	1310/1550	12	20
C2/C3D	Singlemode	1310/1550	17	40
C2/C3H	Singlemode	1310/1550	25	60
L4x3/L4x3	Singlemode	1270-1610 (CWDM)	25	20-70

- Chromatic dispersion as well as other losses should be taken into account when calculating the optical budget.

Video

Specifications	Values
Digital Signals	DVI 1.0 / VESA
Resolutions	(see chart on front side)
Connector	DVI-I
Color Depth	24-Bit
Analog Signal Types	RGBHV / VGA / RGB (with VGA to DVI-I adapter)
VGA Video Bandwidth	780 MHz
Analog Video Output Level	1V p-p
Video Signal-to-Noise Ratio	> 55 dB

Data & Audio

Specifications	Values
Data	RS232
Bandwidth	Up to 20Kbps
Connector Type	RS232 - Terminal block Keyboard/Mouse - USB
Digital Audio	S/PDIF
Input Level	0.2V
Connector Type	RCA
Analog Audio	Dual Channel 24-Bit
Impedance	47k Ohm Unbalanced
Input Level	2V p-p Max
Frequency Response	20 Hz to 20 KHz (+/- 0.1 dB)
Signal-to-Noise Ratio	> 85 dB @ 1 KHz (weighted)
Total Harmonic Distortion	< 0.1% A 1 KHz
Connector Type	1/8" Headphone Jack

Connection Diagram

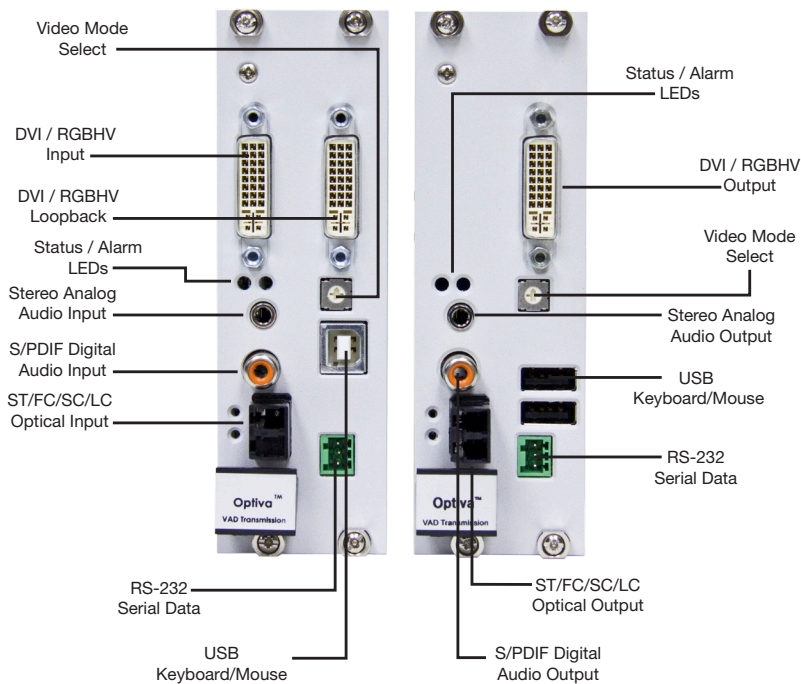

General

Specifications	Values
Dimensions (Insert Card)	6.3"D x 1.6"W x 4.0"H
Weight	22 oz.
Operating Temperature	0° to +50°C
Storage Temperature	-30°C to +85°C
Humidity	0 to 95% (non-condensing)
Power Consumption	~8 Watts
Warranty	3 Years

Monitoring & Control

Specifications	Values
Local	Front panel LED status and alert indicators
Remote	OptivaView SNMP Management Suite*

- * Requires OptivaView SNMP Controller Card (Model: OPV-CTRL)

Compliance (pending)

