

VX Active Optical Cables

DVI Video Extension over Active Optical Cables



DATASHEET

FIBER OPTICS



Features

- Extends VESA video resolutions up to WUXGA 1920 x 1200 @ 60Hz
- Provides lossless and uncompressed image quality without frame dropping
- VXC-1DVI-HC: Up to 100m (326 ft) distance
- VXC-1DVI-OC: Up to 500m (1640 ft) distance
- Complies with HDCP & DDC specifications
- FCC and CE certified for EMI/RFI
- Complies with Class-1 laser safety FDA/CDRH & IEC 60825-1

Applications

- Medical Facility Video Transport
- Digital Theater / Distance Learning Rooms
- Public digital signage displays
- Airport/Train/Other mass-transit facilities
- Digital Signage & Kiosk Displays

Uncompressed DVI Video over Active Optical Cables

The VXC-1DVI optical video extension cable is a multi-core optical fiber DVI signal converter that can send 1 channel of DVI video distances much farther than copper cable. The cables come fully terminated with electro-optical and opto-electrical connector ends. Cables like these can greatly increase the distance DVI signals can travel, but also they reduce the overall cable weight when compared with 24 AWG copper cable.

Model: VXC-1DVI-HC

This model of active cable include "Hybrid" copper/fiber technology, which allows full DDC/HDCP compliance enabling protected content to be displayed up to 100 meters (326 feet) away. Additionally, the cable is powered using the copper element in the cable itself, removing the need to have an external power supply on the receiving end.

Model: VXC-1DVI-OC

This fully optical cable has many advantages, including the ability to connect DVI input/output devices up to 500 meters (1640 feet) away! The optical signals are generated by an 8 channel 850nm VCSEL chip. This allows for maximum bandwidth to be transmitted, enabling crystal-clear uncompressed 1920x1200 @ 60Hz. This cable supports transmission of the DDC signal and EDID information so no configuration or external power sources are required.

VX Active Optical Cables

DVI Video Extension over Active Optical Cables



DATASHEET

FIBER OPTICS

Ordering Information

Model	Description
VXC-1DVI-HC-010	DVI Extension over Active Optical Cable, Hybrid Copper/Fiber cable, 4 fiber cores, 10m
VXC-1DVI-HC-020	DVI Extension over Active Optical Cable, Hybrid Copper/Fiber cable, 4 fiber cores, 20m
VXC-1DVI-HC-030	DVI Extension over Active Optical Cable, Hybrid Copper/Fiber cable, 4 fiber cores, 30m
VXC-1DVI-HC-050	DVI Extension over Active Optical Cable, Hybrid Copper/Fiber cable, 4 fiber cores, 50m
VXC-1DVI-HC-100	DVI Extension over Active Optical Cable, Hybrid Copper/Fiber cable, 4 fiber cores, 100m
VXC-1DVI-HC-XXX	DVI Extension over Active Optical Cable, 8 strand hardened optical cable, XXXm

- Comes with one power adapter

Model	Description
VXC-1DVI-OC-020	DVI Extension over Active Optical Cable, 8 strand hardened optical cable, 20m
VXC-1DVI-OC-030	DVI Extension over Active Optical Cable, 8 strand hardened optical cable, 30m
VXC-1DVI-OC-050	DVI Extension over Active Optical Cable, 8 strand hardened optical cable, 50m
VXC-1DVI-OC-100	DVI Extension over Active Optical Cable, 8 strand hardened optical cable, 100m
VXC-1DVI-OC-500	DVI Extension over Active Optical Cable, 8 strand hardened optical cable, 500m
VXC-1DVI-OC-XXX	DVI Extension over Active Optical Cable, 8 strand hardened optical cable, XXXm

- Comes with two power adapters

“XXX” in the model number designates standard cable lengths available for purchase. Custom lengths may be ordered by changing the values to the correct distance for your project. Distances above 100m only apply to the VXC-1DVI-OC model.

Mechanical Diagram

- VXC-1DVI-HC is designed to use a +5V internal power supplied through a DVI pin (#14) from the graphics card. If the graphics are not sufficient, then plug the supplied power adapter into one of the two modules (Tx or Rx).

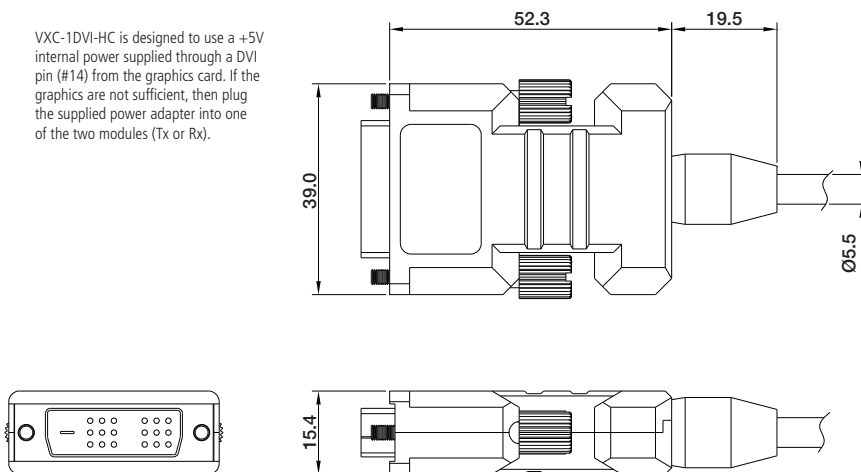

Video

Specifications	Values
Standards	VESA Video Resolutions
Data Rates	1.65Gbps x 4
Connector	24-pin DVI-D (Male)
Max Resolution	1920 x 1200 @ 60 Hz
Signal	TMDS Level (DVI 1.0 Compliant)
Jitter (RCV)	Max. 309 ps
Skew inter-channel	Max. 6 ns

General

Specifications	Values
Dimensions (L x W x H)	2.72" x 1.54" x 0.59" 71.8 x 39.0 x 15.4 mm
Operating Temperature	0° to +50°C
Storage Temperature	-10°C to +75°C
Humidity	5% to 85% (non-condensing)
Input Voltage	5 VDC
Power Consumption	0.9 - 1.1 Watts
Warranty	1 year

Compliance

